



SPECIFICATIONS:

Product codes and related products	
DF-A0001	20-3600 MHz 5-element DF antenna.
DF-A0007	20-3000 MHz 5-element DF antenna, optimised for 2-channel receivers
Electrical:	
Frequency Range	Band 1: 20 – 300 MHz; Band 2: 300 – 1000 MHz; Band 3: 1000 – 3600 MHz
Bands	Band 3: 1000 – 3600 MHz
Nominal input impedance	50 Ω
Antenna Type	5 Element DF Interferometer
Polarisation	Vertical
Output cables	RG 400 cables (Qty 15)
Connectors	TNC male
Mechanical:	
Cross sectional wind load area	0.75 m ²
Maximum wind speed	150 km/h (without ice)
Antenna weight	44.5 kg
Assembled height	2.64 m
Assembled diameter (max)	2.67 m
Packaging Length	1.550 m
Shipping container dimensions	1550 mm x 600 mm x 500 mm
Weight of Tactical DF including wooden container	48 kg 106 kg
Cross Sectional wind load area	0.75 m ²

PRODUCT DESCRIPTION:

This tactical direction finding antenna covers a frequency range of 20 MHz to 3.6 GHz. Shipped in a compact storage and transport box, the antenna can be assembled by one person in 30 minutes, without special tools.

The full-size elements on all bands give excellent DF sensitivity. Ultimate angular resolution for strong signals is well under 1° for most of the frequency range. Dipole elements provide good cross-polarisation rejection, and fair performance for signals arriving from up to 15° above or below the horizon.

This DF antenna is designed to be used with a 5-channel phase-sensitive receiver, and correlative algorithm. Calibration of the antenna can be performed on request.

ELECTRICAL FEATURES:

- Full size DF with
- Wide band DF
- 5 Element Interferometer

MECHANICAL FEATURES:

- Robust Construction
- Waterproof
- Quick Assembly

Tactical Direction Finding Antenna

20 – 3600 MHz

Product Code: DF-A0001

VERSION: 2.2

DF antenna dimensions

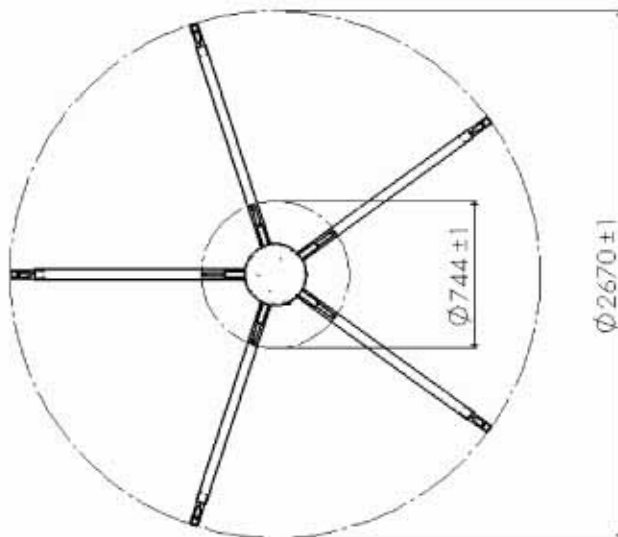
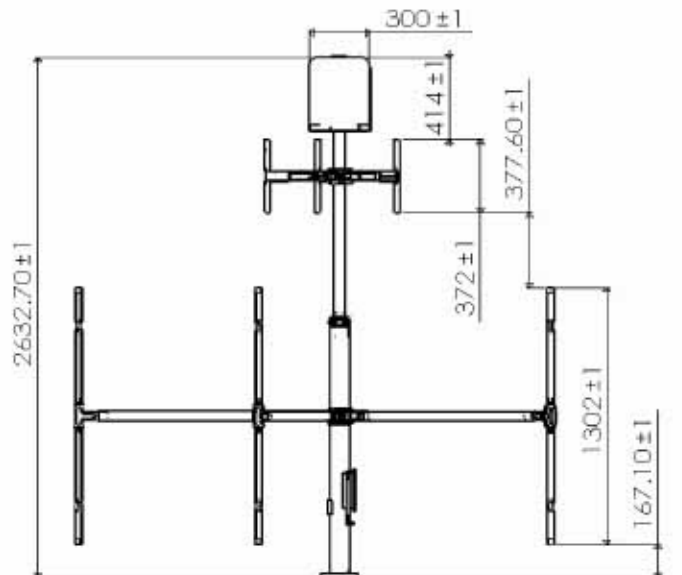

Tactical Direction Finding Antenna

20 – 3600 MHz

Product Code: DF-A0001

VERSION: 2.2

DF sensitivity graph:

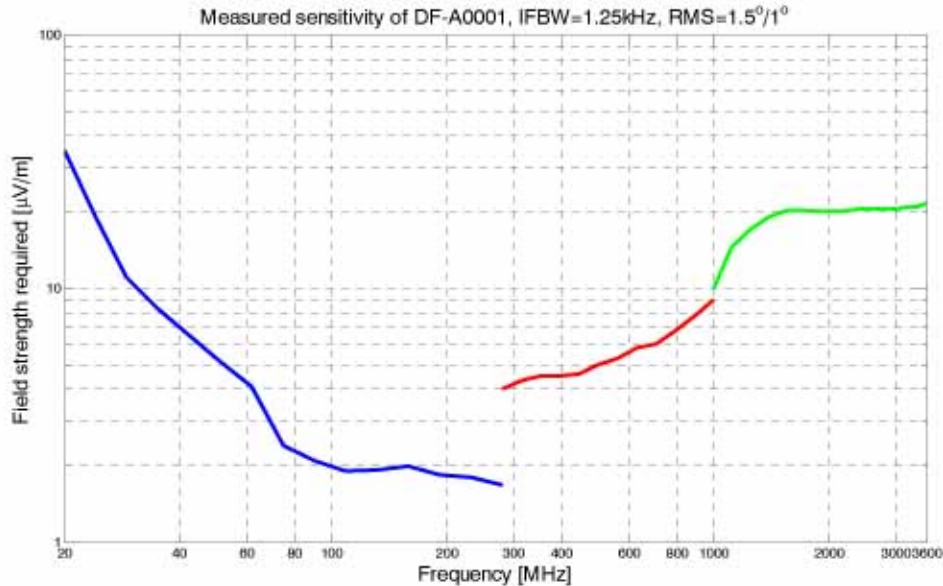

The graph illustrates the direction finding sensitivity of a typical system measured under specific electrical conditions.

The sensitivity is measured using an IF bandwidth of 1.25 kHz and without averaging.

The graph shows the minimum signal required to obtain a bearing fluctuation of less than 1.5° for the frequency range 20 - 280 MHz and less than 1° for the frequency range 280 – 3600 MHz

Environmental Testing Specifications:

Vibration	MIL-STD 810E method 516.4, category 8
Mechanical Shock	MIL-STD 810E method 516.4 (40 g)
Low temperature storage	MIL-STD 810E method 502.3 (-30 °C)
High Temperature Storage	MIL-STD 810E method 501.3 (+70 °C)
Rain	MIL-STD 810E 506.3 procedure I (95 % RH)
Artificial weathering (UV Stability) total duration 500 h	BS 3900 : Part F16, method A, lamps : UV-B (313) Product exceeds requirements set out by the British Standard
Temperature and Humidity	MIL-STD 810E method 507.3
Salt / fog	MIL-STD 810E 509.3 procedure I
Dust	MIL-STD 810E 510.3 procedure II

Two-channel version, DF-A0007

A version of the antenna is available with band C optimised for operation with a commutated 2-channel receiver.

Special attention has been paid to the nulls which usually occur in this band. Types of receiver system with two channels, commutated to measure five antennas, are sensitive to nulls in the element patterns. Depending on the receiver and algorithm, reducing the null depth leads to a more reliable system.

This band-C element only operates correctly up to 3 GHz.

